



INSTALLATION INSTRUCTIONS

For use with:

ES2-BU1SC30B-3 | ES2-BU2SC30B-3
ES2-BU1SC72B-3

WHAT'S IN THE BOX

- LED EMERGENCY LIGHTING UNIT

WHAT YOU'LL NEED

- SCREWDRIVER / POWER DRILL
- WIRE CUTTERS
- WIRING SUPPLIES AS PER ELECTRICAL CODE

WARNING

Read and Follow All Safety Instructions:

- Unit is for indoor use only.
- Do not let power cords touch hot surfaces.
- Do not install near gas or electric heaters.
- Use caution when servicing batteries. Battery acid can cause burns to skin and eyes. If acid is spilled on skin or eyes, flush acid with fresh water and contact a physician immediately.
- Equipment should be mounted in locations and at heights where unauthorized personnel will not readily subject it to tampering.
- The use of accessory equipment not recommended by manufacturer, may cause an unsafe condition, and will void the unit's warranty.
- Servicing of this equipment should be performed by qualified service personnel.

To Avoid Voiding the Warranty:

- Circuit feeding unit must be protected by lock-on breaker. If the breaker feeding this unit does not have a lock-on device, warranty will be voided.

IMPORTANT

Before assembling your emergency lighting unit, please make sure that you carefully read through this instruction sheet. This unit must be installed by a qualified licensed electrician.

This luminaire is suitable for use in the following locations: indoor, dry or damp locations.

UNIT OVERVIEW

This emergency light is constructed with steel housing and lightweight thermal plastic head in matching color. It is presented a simple and modern design with high efficiency LED remote heads. Universal mounting pattern and keyhole slots are stamped on the back and conduit knockouts on the sides of each unit.

Circuitry

Input Voltage	ES2-BUxSC30B-3
AC 120V 50/60Hz	Input Wattage : 3.2W
	Input Current : 0.03A
	Efficiency : 0.97P
AC277V 50/60Hz	Input Wattage : 3.3W
	Input Current : 0.01A
	Efficiency : 0.92P
AC347V 50/60Hz	Input Wattage : 3.6W
	Input Current : 0.01A
	Efficiency : 0.92P

Wiring Diagram

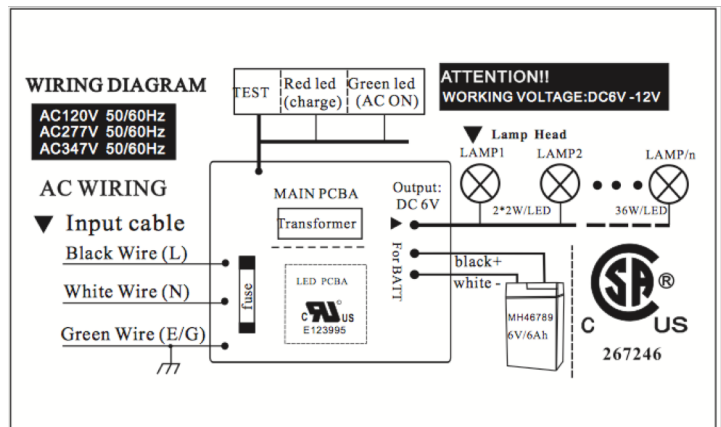

TO INSTALL THE UNIT

1. Extend un-switched 20 hour AC supply of rated voltage to a junction box (supplied by others) installed in accordance with all applicable codes and standards. Leave a minimum of 8 inches of slack on the wire. This circuit should NOT be energized/live at this time.
2. Open the unit by unscrewing the cover screws on the sides of the unit. The front cover can then be removed.
3. Unit is supplied with universal spider knockouts and keyhole slots stamped into the back of the cabinet. Knock out the appropriate hole(s) and bring wires through the hole(s) into the cabinet.
4. Mount the unit securely into place. Do not rely on the electrical box as the only support for the unit.
5. Make proper wiring connections between the AC supply and the unit's transformer: White、 Black -Line 120V-347 Volts; Green - Line Earth (refer to Wiring Diagram).

TO INSTALL THE UNIT (continued)

6. Ensure all unused wires are insulated. Connect ground to supplied green ground wire in accordance with local codes. Reassemble all wire connections and connectors. Failure to insulate unused wire may result in a shock hazard or unsafe condition as well as well as equipment failure.
7. Ensure you connect the batteries already installed in the cabinet to the circuit board (refer to Wiring Diagram).
8. Secure all internal wires and replace cover and secure cover screws.
9. Turn on AC line voltage supply.
10. Position the lamp heads to provide best lighting distribution by loosening head set screws to adjust angle and swivel. Manually rotate or turn head(s) to the desired position, then tighten set screws to lock position.

The unit can be wall or pendant mounted. See diagrams below for mounting instructions.

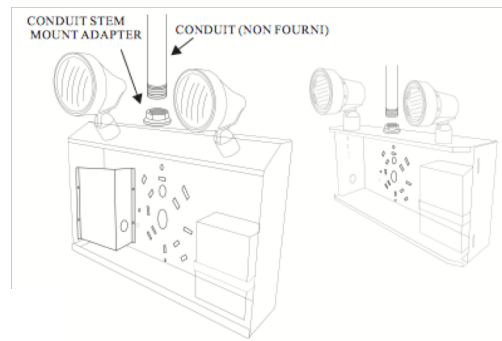
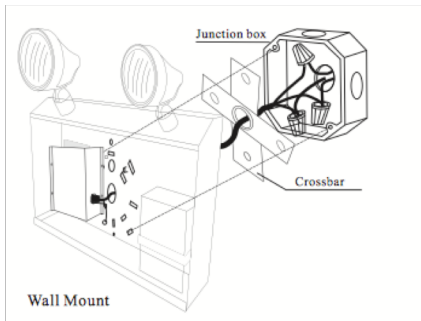

Installation now complete. Proceed to the TO OPERATE THE UNIT section of this sheet.

TO OPERATE THIS UNIT

This unit is furnished with a sophisticated low voltage battery dropout circuit to protect the battery from over-discharge after the useful output has been used. **Allow 20 hours recharge time after installation or power failure for full-load testing or usage.**

1. To Test, depress the TEST Switch. Charge indicator will go out and the DC lamps will come on.
2. Release the TEST Switch. DC lamps will be extinguished, and the charge indicator will come on.
3. A bright charge LED indicator light indicates a high charge rate. After the battery has reached full charge, the indicator light will go out. Under normal operation the high charge indicator will turn on and off intermittently while the unit is in standby mode (regular AC is present) since the charge rate will vary in order to maintain an optimal battery performance.

TO MAINTAIN THIS UNIT

1. Most Codes require that the equipment be tested every 30 days for 30 seconds, and that written records be maintained for all test results and repairs. Further, the equipment is to be tested once a year for the required duration as per Code. The battery is to be replaced or the equipment repaired whenever the equipment fails to operate as intended during the duration test. The manufacturer strongly recommends compliance with all Code requirements.
2. Clean lenses on a regular basis to provide maximum light distribution in case of an emergency.

NOTE:

The servicing of any parts should be performed by qualified service personnel only. The use of replacement parts not furnished by the manufacturer, may cause equipment failure and will void the warranty.