



SEN Screw-in PIR Motion Sensor: Stand-alone

HIGHLIGHTS

- Screw-in PIR Motion Sensor for Stand-alone Controls
- Designed for use with EiKO's fixtures screw-in receptacle for quick and easy installation in the field
- Features passive infrared technology; used for automatically turning the lights on when occupancy is detected and off when there is no occupancy detected
- Field adjustable settings included: brightness (high-end trim), dim level, sensitivity, hold time, and dim time for customized lighting control
- Dual ambient and daylight sensing technology improves accuracy in outdoor applications when the sensor is within the range of artificial light emitted from the fixture, resulting in a more energy-efficient and reliable lighting system
- Daylight harvesting for energy efficiency*
- Occupancy detection can be disabled, and the sensor can function as a photocell alone
- Photocell function can be used as traditional dusk-to-dawn or two-stage dimming/midnight dimming
- Robust design for reliable operation in various environments
- Supports maintenance-friendly features such as remote commissioning

CERTIFICATIONS

- UL listed for US & Canada
- RoHS Compliant
- FCC Compliant
- IP65 Rated

PERFORMANCE

- Mounting Height: 8-40ft
- 0-10V Bi-Level Dimming
- 360° Coverage Pattern

ELECTRICAL

- Input Voltage: 12-24VDC
- Input Current: 50mA
- Dimming: 0-10V
- Remote Control: SEN5A-ACT (Purchased Separately)

THERMAL

- -4°F to 140°F (-20°C to 60°C) operating temperature

CONSTRUCTION

- High strength, UV-resistant white polycarbonate housing
- Screw-in installation

COMPATIBILITY

- Fixtures: AAL1, PG1, LH1, LHC1, HBV2, BAYE3, HBX2, HBX3, FL5, and SIG2

FACTORY DEFAULT SETTINGS

- Brightness: 100%
- Sensitivity: 75%
- Hold Time: 10 minutes
- Daylight Function: Disable
- Dim level: 30%
- Dim Time: 1 minute

WARRANTY

- 5-Year limited warranty available [online](#). Contact your EiKO sales rep for additional details.

project name	type
catalog number	voltage
approved by	date



APPLICATIONS

- Warehouse
- Manufacturing Plants
- Distribution Centers
- Gymnasiums
- Parking Garage
- Parking Lots
- Car Dealerships
- Athletic Facilities and Sports Field
- Big Box Retail
- Service Repair Center

* For detailed instructions on how to configure the daylight harvesting setting, please refer to the [SEN5A-ACT Operation Instructions](#).

KEY FEATURES

SCREW-IN DESIGN

Makes adding a stand-alone control solution simple and easy; to be used with fixtures that can accommodate a screw-in control solution (see above for compatibility).

EASILY CHANGE FACTORY DEFAULT SETTINGS

Simply use the commissioning tool (purchased separately) to change brightness (high-end trim), dim level, sensitivity, hold time, and dim time; once you have your settings locked into the commissioning tool then aim at each sensor individually to program.

SENSOR CUSTOMIZATION

Dual ambient and daylight sensing technology featuring daylight harvesting, occupancy detection or photocell alone. Photocell function can be used as a traditional dusk-to-dawn or two-stage dimming/midnight dimming.



AVAILABLE MODELS

ORDER	ORDER CODE	ITEM #	INPUT VOLTAGE	SENSOR TECHNOLOGY	DAYLIGHT HARVESTING	DIMMING	MOUNTING HEIGHT	INSTALLATION TYPE
	13861	SEN5A-SPPR-WH	12-24VDC	PIR	YES	0-10V	8-40ft	Screw-in

ACCESSORIES

ORDER	ORDER CODE	ITEM #	DESCRIPTION
	14431	SENA-AP-WH	Screw-In IP65 White Stem Swivel Mounting bracket 12-24VDC Max. 22AWG 2ft V+(1:Yellow) Dim-(2:Pink) Dim+(3:Purple)
	13344	SEN5A-ACT*	Commissioning Tool for SEN5A, BAY-E-SEN/PIR, BAY-E-SEN/M, and MS2-DPX-3 (Backward compatible with SEN5A/CT and RC-100)

* Commissioning tool required for making changes to factory default settings. See page 3 for commissioning.

PRODUCT DIMENSIONS

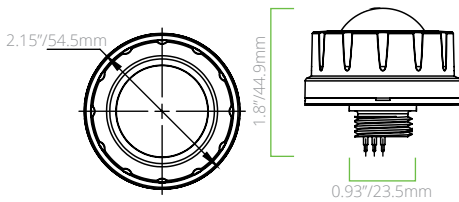

PIN DIMENSIONS

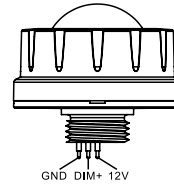

SEN5A-SPPR-WH

SENSOR DETECTION COVERAGE

COVERAGE SIDE VIEW

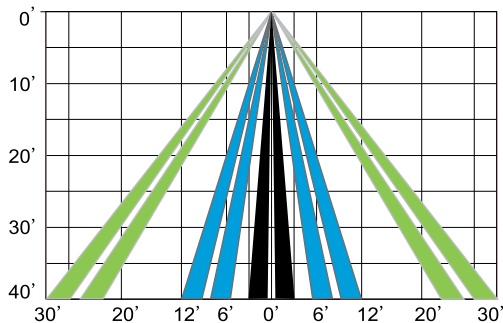

- Minor Motion Cone Center
- Minor Motion
- Major Motion

COVERAGE TOP VIEW

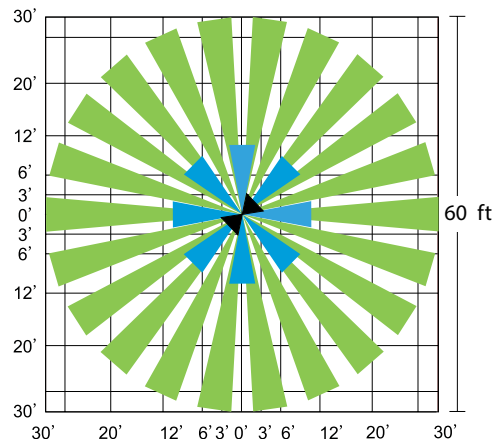

Note: For the best performance, it is recommended to mount the sensor between 20-35ft in height. Low mounting can result in narrow detection coverage, while mounting the sensor higher than 40ft may limit the detection coverage to only the sensor center cone area.

INSTALLATION INSTRUCTIONS

- 1** Use a Philips screwdriver, loosen the 1/2" sensor cover.

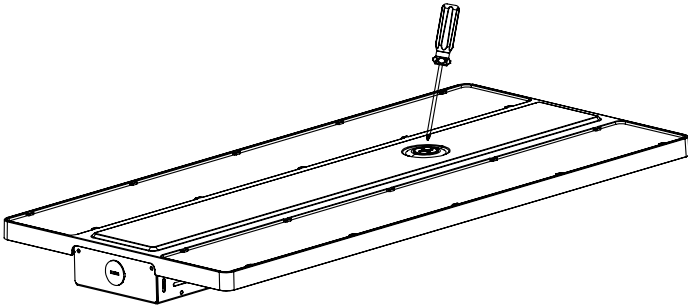

- 2** Take out the 1/2" sensor cover.

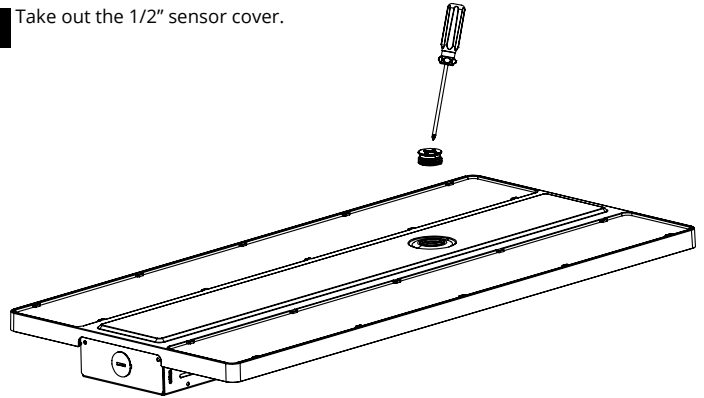

- 3** Align the sensor with the sensor receptacle.

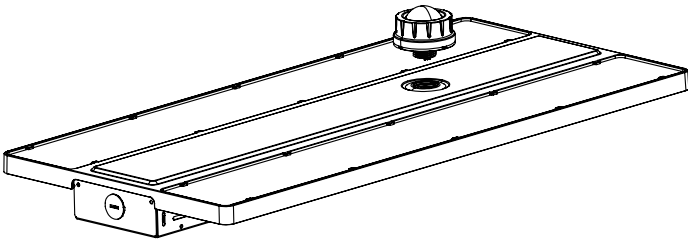

- 4** Securely screw the sensor in place.

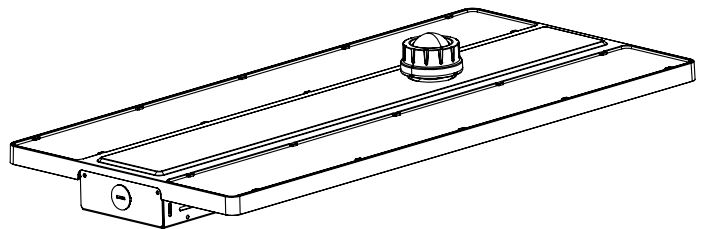

COMMISSIONING:

Scan QR code below or click [here](#) for detailed commissioning instructions. Commissioning tool required.



SEN5A-ACT



FCC STATEMENT

- This device complies with Part 15 of the FCC Rules. Operation is subject to the following two conditions:
 - (1) This device may not cause harmful interference.
 - (2) This device must accept any interference received, including interference that may cause undesired operation.
- This device complies with Part 15 of the FCC Rules. Operation is subject to the following two conditions: (1) this device may not cause harmful interference, and (2) this device must accept any interference received, including interference that may cause undesired operation.
- **Caution:** The user is cautioned that changes or modifications not expressly approved by the party responsible for compliance could void the user's authority to operate the equipment. Note: This equipment has been tested and found to comply with the limits for a Class B digital device, pursuant to part 15 of the FCC Rules. These limits are designed to provide reasonable protection against harmful interference in a residential installation. This equipment generates uses and can radiate radio frequency energy and, if not installed and used in accordance with the instructions, may cause harmful interference to radio communications. However, there is no guarantee that interference will not occur in a particular installation. If this equipment does cause harmful interference to radio or television reception, which can be determined by turning the equipment off and on, the user is encouraged to try to correct the interference by one or more of the following measures:
 - Reorient or relocate the receiving antenna.
 - Increase the separation between the equipment and receiver.
 - Connect the equipment into an outlet on a circuit different from that to which the receiver is connected.
- This device contains licence-exempt transmitter(s)/receiver(s) that comply with Innovation, Science and Economic Development Canada's licence-exempt RSS(s). Operation is subject to the following two conditions:
 - (1) This device may not cause interference.
 - (2) This device must accept any interference, including interference that may cause undesired operation of the device.
- L'émetteur/récepteur exempt de licence contenu dans le présent appareil est conforme aux CNR d'Innovation, Sciences et Développement économique Canada applicables aux appareils radio exempts de licence. L'exploitation est autorisée aux deux conditions suivantes :
 - (1) L'appareil ne doit pas produire de brouillage;
 - (2) L'appareil doit accepter tout brouillage radioélectrique subi, même si le brouillage est susceptible d'en compromettre le fonctionnement.
- To satisfy FCC&IC RF exposure requirements, a separation distance of 20 cm or more should be maintained between the antenna of this device and persons during device operation. To ensure compliance, operations at closer than this distance is not recommended. Les antennes installées doivent être situées de façon à ce que la population ne puisse y être exposée à une distance de moins de 20 cm. Installer les antennes de façon à ce que le personnel ne puisse approcher à 20 cm ou moins de la position centrale de l'antenne.