



BLD Emergency LED Driver

HIGHLIGHTS

- Meet most of safety standards for lighting
- Standard CSA C22.2 NO.141, UL924
- External LiFePO4 battery
- Battery protections: over charge protection, over discharge protection
- Indicator shows a variety working modes
- The batteries meet 500 cycles of standard charge and discharge
- RoHS compliant

CERTIFICATIONS

- UL listed for US & Canada
- RoHS Compliant

PERFORMANCE

- Universal Input Voltage - 100-34 7Vac,50/60Hz
- AC Input Current - 100mA max. AC
- Input Power Rating - 7.0W max.
- Emergency Time -1.5H
- Battery Charging Current - 250mA
- Charging Time 24Hours

THERMAL

- 5°C to +60°C (41 °F to 140°F) ambient operating temperature

WARRANTY

- 5 Year limited warranty available [online](#). Contact your EiKO sales rep for additional details.

project name	type
catalog number	voltage
approved by	date



APPLICATIONS

- Strip fixture
- Vapor Tight fixture
- Wall Pack

AVAILABLE MODELS

ORDER CODE	MODEL	INPUT VOLTAGE	OUTPUT VOLTAGE	OUTPUT POWER	BATTERY SIZE
14564	BLD-CM08E-YYY	100-347Vac	36-56Vdc	8W	Type A

EMERGENCY DRIVER

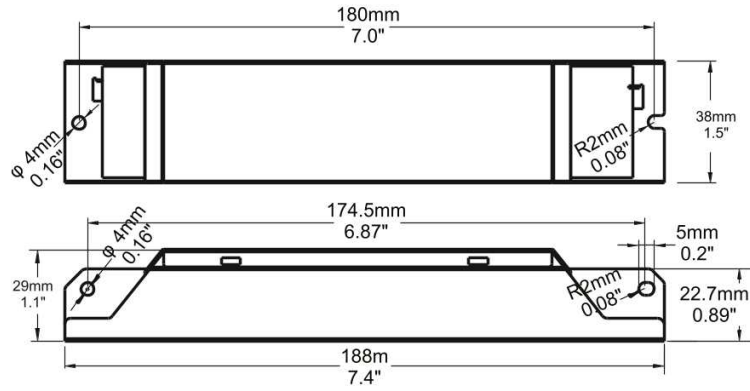

BATTERY PACK

