



WFC1 Full Cutoff Wall Pack

HIGHLIGHTS

- Full cutoff optics to reduce glare, light pollution and improve visibility
- Hinged junction box makes installation and maintenance easier
- Multiple knockouts available for various installations
- Leveling made easy with internal level
- Integrated photocell for dusk to dawn operation
- PowerSet feature allows for multiple “set and forget” lumen stops in each fixture
- FieldCCeT feature allows for multiple “set and forget” CCT options in each fixture

CERTIFICATIONS

- ETL listed for US & Canada
- RoHS compliant
- FCC compliant
- ICES-005 compliant
- IP65 Rated
- IK10 Impact Rating
- DesignLights Consortium® Premium Qualified - meets the requirements for the highest DLC qualification for efficacy and lumen maintenance
- DesignLights Consortium® Luna (Model #14557)

PERFORMANCE

- High efficacy, up to 130 lm/W
- Available in PowerSet model: power-selectable 70/60/45W
- Available in single CCT models: 3000K or FieldCCeT models: field-selectable CCT 30/40/5000K
- CRI: >80
- Beam Angle: NEMA 7H x 6V
- Rated Life: >54,000 Hours

ELECTRICAL

- Input voltage: 120-347V
- 0-10V dimming, dim-to-off
- Surge protection: 4kV
- Power factor: >0.9
- THD: <20%

THERMAL

- -40°F to 104°F (-40°C to 40°C) operating temperature

CONSTRUCTION

- Bronze powder coated, die-cast aluminum housing
- Impact resistant polycarbonate lens
- IK10 impact rating

DIMMING

- For dimming compatibility visit eiko.com

WARRANTY

- 5-Year limited warranty available online. Contact your EiKO sales rep for additional details.

KEY FEATURES

SELECTABLE CCT AND WATTAGE

Choose your CCT and Wattage upon install; great for SKU reduction and job site flexibility

INSTALLATIONS MADE EASY

Mounts directly to junction box or there are multiple knockouts for conduit wiring. Internal level helps ensure precision leveling and hinged door makes maintenance easy

DESIGNED WITH THE ENVIRONMENT IN MIND

Powder coated, die-cast aluminum housing, impact resistant polycarbonate. Full cutoff optics reduce glare, light pollution, and improves visibility (DLC LUNA Model #14557)



project name	type
catalog number	voltage
approved by	date



APPLICATIONS

- Industrial Parks
- Loading Docks
- Utility Sheds
- Entryways
- Walkways
- Storage Areas
- Security

AVAILABLE MODELS

ORDER	ORDER CODE	ITEM #	WATTS*	CCT**	LUMENS	EFFICACY (lm/W)	VOLTAGE	TRADITIONAL WATTAGE EQUIVALENT	DLC ID #
									PREMIUM
	13461	WFC1-PS70-FCCT-H	70/60/45W	30/40/5000K	9100/7800/5850 lm	130 lm/W	120-347V	Up to 250W HID	S-5AQYOW
	14557	WFC1-PS70-30-H***	70/60/45W	3000K	9100/7800/5850 lm	130 lm/W	120-347V	Up to 250W HID	S-FX46E2

* All power-selectable fixtures ship at the highest wattage setting

** All CCT-selectable fixtures ship at 3000K

*** Model for DLC Luna

MODEL CONFIGURATOR						
MODEL	-	WATTAGE	-	CCT	-	VOLTAGE
WFC1	-		-		-	

EXAMPLE PART NUMBER: WFC1-PS70-FCCT-H

PRODUCT DIMENSIONS

12.6" / 320mm

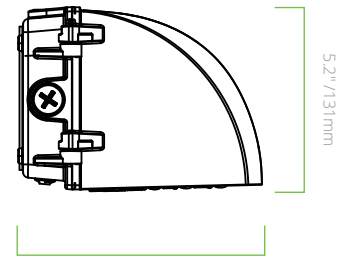
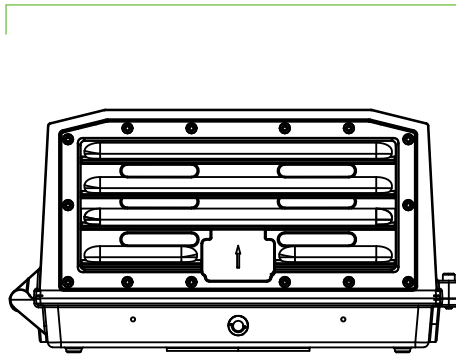

6.8" / 173mm

WFC1- ALL MODELS

Weight: 5.29 lbs / 2.4 kg