



CD Commercial Downlight

HIGHLIGHTS

- Provides comfortable diffused light
- PowerSet feature allows for 5 "set and forget" lumen stops *
- FieldCCeT feature allows for 5 "set and forget" CCT options **
- Suitable for new construction or remodel applications
- Flexible steel conduit with 1/2" KO (3/8" Trade Size) snap in connector
- Easy Installation due to spring-loaded heavy duty brackets that keep the downlight in place
- Multiple sizes to fit various applications (4", 6", 8" and 10" models)
- Deep recessed light source for lower glare

CERTIFICATIONS

- ETL
- ENERGY STAR® Approved for superior energy efficiency
- IC Rated for direct contact with insulation
- Wet Location
- RoHS Compliant
- FCC Compliant
- ICES-005 Compliant
- IP54 Rated

PERFORMANCE

- High efficacy, up to 100 lm/W
- PowerSet: 40/35/30/25/20W, 35/30/25/20/15W, 20/18/16/14/12W, 16/14/12/10/8W
- FieldCCeT: 27/30/35/40/5000K
- CRI: >80
- Beam Angle:
 - 4", 6" = 90°
 - 8", 10" = 100°
- Estimated L70: 100,000 Hours

ELECTRICAL

- Input Voltage: 120-277V, 120-347V
- Dimming: 0-10V (120-277V models), 0-10V + Triac (120-347V models)
- Surge Protection: 2.5kV
- Power Factor: >0.9
- THD: <20%

THERMAL

- -4°F to 113°F (-20°C to 45°C) ambient operating temperature

CONSTRUCTION

- Powder coated aluminum reflector and trim
- Designed as one complete unit: driver, housing and lens

WARRANTY

- 5-Year limited warranty available [online](#). Contact your EiKO sales rep for additional details.

* PowerSet models ship preset at the highest wattage.

** FieldCCeT models ship preset at 5000K

project name	type
catalog number	voltage
approved by	date

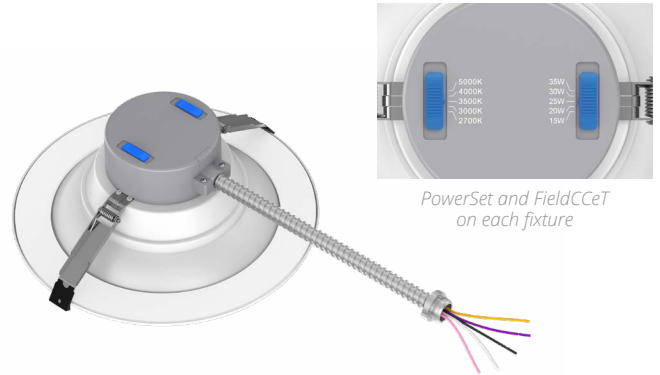

PowerSet and FieldCCeT on each fixture



APPLICATIONS

- Reception/Lobby
- Retail/Storefront
- Dr. Offices/Waiting/Patient Rooms
- Admin/Class/Conference/Meeting Rooms/Library
- Multi-Residential (Dorms/ Apartments)
- Gyms & Athletic Facilities
- Industrial/Commercial Offices

MODEL CONFIGURATOR											
MODEL	SIZE	-	POWERSET	-	CRI	FIELDCCET	-	VOLTAGE	DIMMING	-	COLOR
CD : Commercial Downlight	4 - 4"	-	PS16 - 16/14/12/10/8W	-	8 - 80+	FCCT - 27/30/35/40/5000K	-	U - 120-277V	DIM - 0-10V	-	WH - White
	6 - 6"		PS20 - 20/18/16/14/12W								
	8 - 8"		PS40 - 40/35/30/25/20W								
	10 - 10"		PS35 - 35/30/25/20/15W								
			PS40 - 40/35/30/25/20W					H - 120-347V*	DD - Triac & 0-10V		

*Note: see available models table for specific models that are 120-347V

AVAILABLE MODELS

ORDER	ORDER CODE	ITEM #	SIZE	WATTS (W)	LUMENS (lm)	EFFICACY (lm/W)	CRI	CCT (K)	DIMMING	VOLTAGE (VAC)	ENERGY STAR
	15156	CD4-PS16-8FCCT-UDIM-WH	4"	16/14/12/10/8	1440/1260/1080 /900/720	90	80	27/30/35/40/50	0-10V	120-277	★
	15157	CD6-PS20-8FCCT-UDIM-WH	6"	20/18/16/14/12	2000/1800/1600 /1400/1200	100	80	27/30/35/40/50	0-10V	120-277	★
	15158	CD6-PS20-8FCCT-HDD-WH	6"	20/18/16/14/12	2000/1800/1600 /1400/1200	100	80	27/30/35/40/50	Triac & 0-10V	120-347	★
	15163	CD6-PS40-8FCCT-UDIM-WH	6"	40/35/30/25/20	4000/3500/3000 /2500/2000	100	80	27/30/35/40/50	0-10V	120-277	★
	15165	CD6-PS40-8FCCT-HDD-WH	6"	40/35/30/25/20	4000/3500/3000 /2500/2000	100	80	27/30/35/40/50	Triac & 0-10V	120-347	★
	15167	CD8-PS35-8FCCT-UDIM-WH	8"	35/30/35/20/15	3500/3000/3500 /2000/1500	100	80	27/30/35/40/50	0-10V	120-277	★
	15169	CD8-PS35-8FCCT-HDD-WH	8"	35/30/35/20/15	3500/3000/3500 /2000/1500	100	80	27/30/35/40/50	Triac & 0-10V	120-347	★
	15171	CD10-PS40-8FCCT-UDIM-WH	10"	40/35/30/25/20	4000/3500/3000 /2500/2000	100	80	27/30/35/40/50	0-10V	120-277	★

ACCESSORIES

ORDER	ORDER CODE	ITEM #	DESCRIPTION	
	15198	DL4-GR-WH	4" Goof Ring White	
	15199	DL6-GR-WH	6" Goof Ring White	
	15205	DL8-GR-WH	8" Goof Ring White	
	15203	DL-NCPSJ	New Construction Plate Stud/Joist	
	15201	DL-NCPTG	New Construction Plate T-Grid Accessory	

BATTERY BACKUPS

ORDER	ORDER CODE	ITEM #	DESCRIPTION
	11674	EEBE08WHA170S	EiKO Emergency Battery External 8W 120-347V 170VDC Single Flex-Conduit CEC Compliant. Field install.
	11675	EEBE18WHA170S	EiKO Emergency Battery External 18W 100-347V 170VDC Single Flex-Conduit CEC Compliant. Field install.

PRODUCT DIMENSIONS

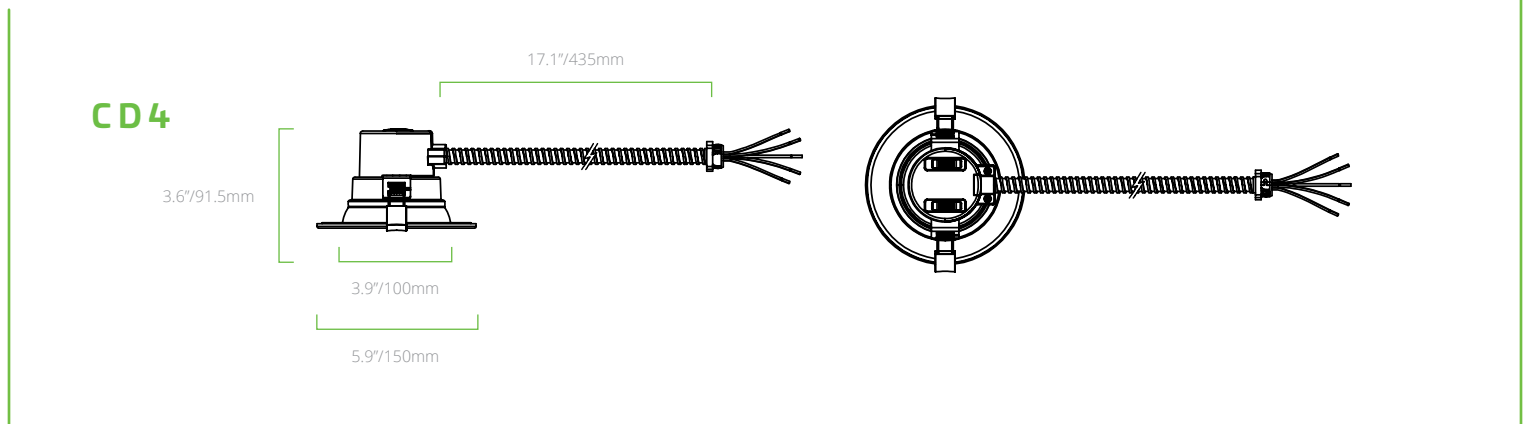

PRODUCT DIMENSIONS CONT'D

CD6

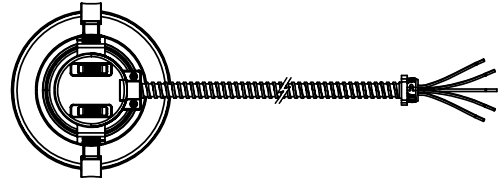
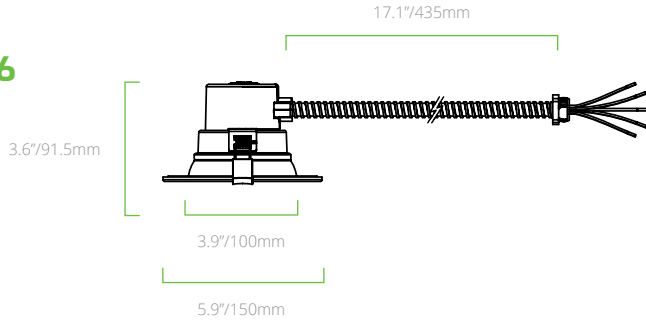

CD8

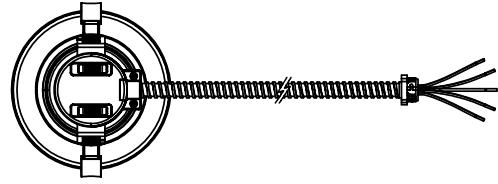
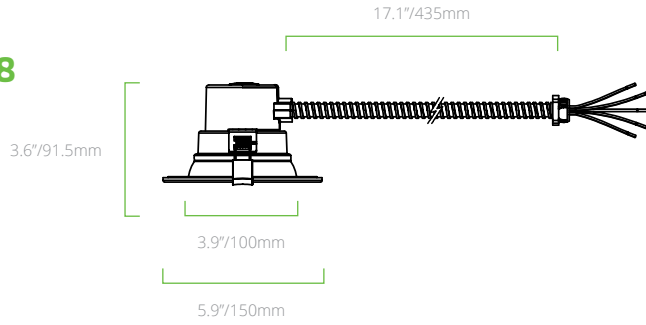

CD10

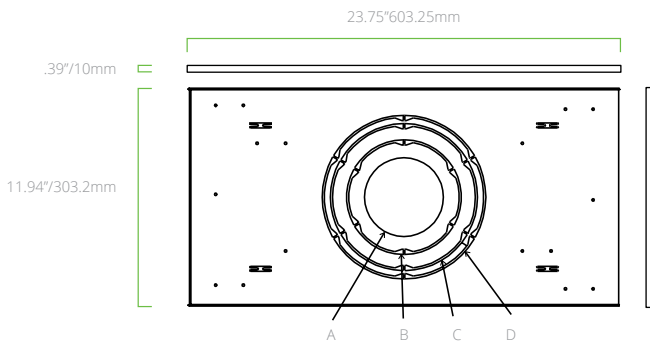
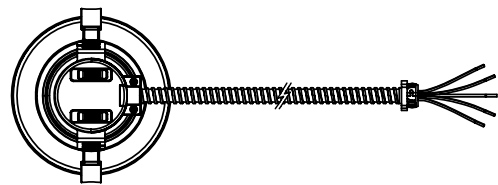
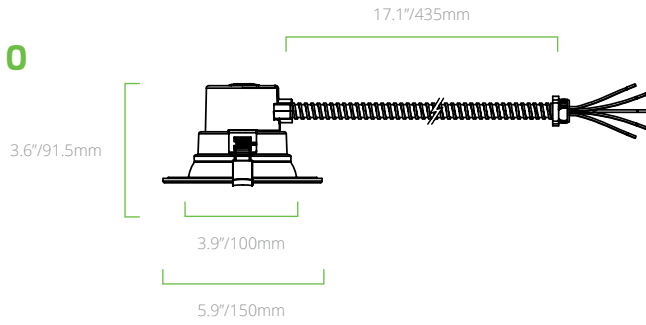

DL-NCPTG
NEW CONSTRUCTION PLATE T-GRID

A: Ø 4 5/16"/109.54mm C: Ø 8 1/16"/204.79mm
B: Ø 6 5/16"/160.34mm D: Ø 9"/228.6mm

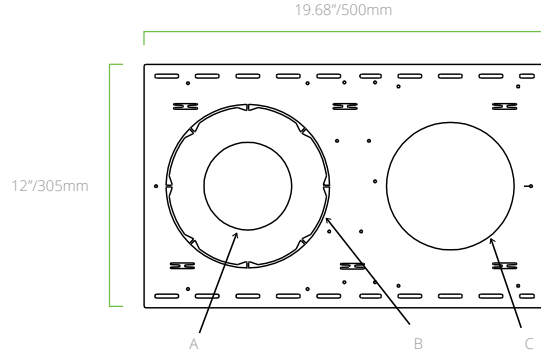

DL-NCPSJ
NEW CONSTRUCTION PLATE STUD/JOIST

A: Ø 4 5/16"/109.54mm
B: Ø 8 1/16"/204.79mm
C: Ø 6 5/16"/160.34mm



Goof Ring 4"

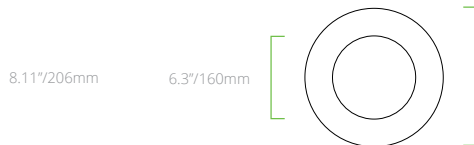

Goof Ring 6"

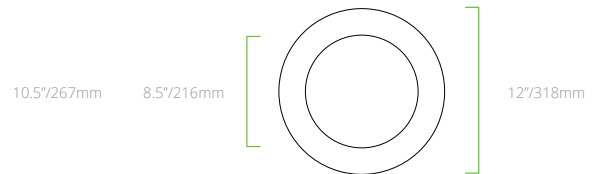

Goof Ring 8"